



FITTING INSTRUCTIONS FOR ECS0123BK ENGINE CASE SLIDERS
KTM RC390 '17- (RIGHT HAND SIDE ONLY)



THIS KIT CONTAINS THE ITEMS PICTURED AND LABELLED BELOW.
DO NOT PROCEED UNTIL YOU ARE SURE ALL PARTS ARE PRESENT.

Please note that the way the kit is packed does not necessarily represent the way of mounting to the bike.

THE PARTS SHOWN MAY BE REPRESENTATIVE ONLY (FOR CLARITY OF INSTRUCTIONS ONLY).

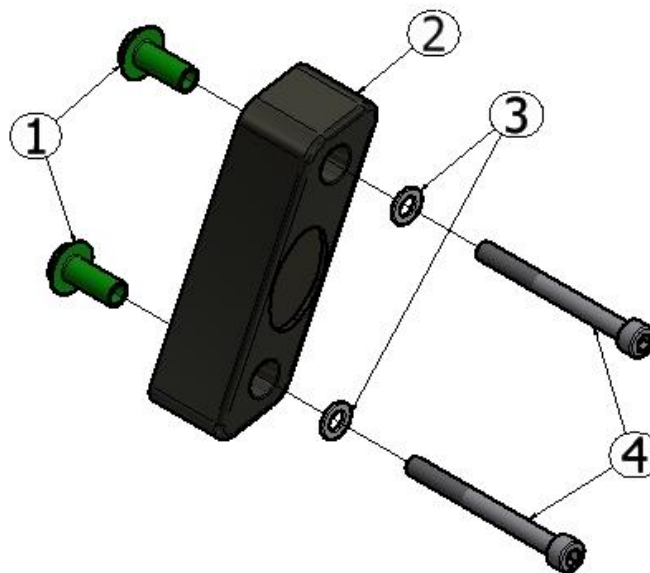



LEGEND

ITEM 1 = COMP SLEEVE (*PRE-FITTED*) (CS514) (x2).

ITEM 2 = ENGINE CASE SLIDER (ECS0123) (x1).

ITEM 3 = M6 WASHERS (x2)

ITEM 4 = M6 x 60mm LONG CAP HEAD BOLTS (x2).

TOOLS REQUIRED

- Socket set to include 4, 5mm A/F socket & wrench.
 - 8mm spanner or socket & wrench.



FITTING INSTRUCTIONS

Right side (as you sit on bike)

- Remove the two bolts on the right hand side engine case as arrowed in picture 1
- If not already fitted, locate the comp sleeves (Item 1) to the new engine case slider (Item 2) in positions as shown in the exploded diagram on page 1.
- Offer the engine case slider (Item 2) in position on the right hand side engine case.
- Insert one bolt (item 4) with a washer (item 3) into each mounting hole of the engine case slider. Tighten both bolts evenly and torque them up to a maximum of 15Nm.
- Place the bubble sticker in the allocated profile of the slider
- Ensure that the assembled components match the exploded diagram shown on page 1.

Issue 1 24/08/2017 (HH)

Digital copies of these instructions are available to download from www.rg-racing.com

CONSUMER NOTICE

The catalogue description and any exhibition of samples are only broad indications of the Products and R&G may make design changes which do not diminish their performance or visual appeal and supplying them in such state shall conform to the order. The Buyer acknowledges no representation or warranty (other than as to title) has been given or will apply to the Products other than those in R&G's order or confirmation and the Buyer confirms it has chosen the Products as being of merchantable quality and suitable for its particular purposes. Where R&G fits the Products or undertakes other services it shall exercise reasonable skill and care and rectify

R&G Racing

Unit 1, Shelley's Lane, East Worldham, Alton, Hampshire, GU34 3AQ

Tel: +44 (0)1420 89007 Fax: +44 (0)1420 87301 www.rg-racing.com Email: info@rg-racing.com



any fault free of charge unless the workmanship has been disturbed. The Buyer is responsible for ensuring that the warranty on the motorcycle is not affected by the fitting of the Products. On return of any defective Products R&G shall at its option either supply a replacement or refund the purchase money but shall not be liable if the Products have been modified or used or maintained otherwise than in accordance with R&G's or manufacturer's instructions and good engineering practice or if the defect arises from accident or neglect. Other than identified above and subject to R&G not limiting its liability for causing death and personal injury, it shall not be liable for indirect or consequential loss and otherwise its liability shall be limited to the amounts paid by the Buyer for the Products or the fitting or service concerned. These terms do not affect the Buyer's statutory rights.

R&G RACING RETURNS POLICY (NON-FAULTY GOODS)

Returns must be pre-authorized (if not pre-authorized the return will be rejected). Goods may only be returned direct to us if they were purchased direct from us (customer must prove if necessary). Otherwise to be returned to original vendor. Goods must be in re-sellable condition, in the opinion of R&G Racing. All returns are subject to a 25% restocking and handling fee (25% of the gross value exc. P&P – at the prevailing price at time of purchase). The customer must pay any and all carriage charges. No returns of discontinued products, unless within 14 days of purchase. This policy does not affect your statutory rights and does not refer to faulty goods.



**NOTICE DE MONTAGE POUR ECS0123BK SLIDERS DE CARTER MOTEUR
KTM RC390 '17- (CÔTÉ DROIT UNIQUEMENT)**



Le kit contient les articles exposés ci-dessous, vérifier que toutes les pièces soient présentes avant de procéder au montage.

La façon dont le kit est emballé ne correspond pas forcément à la façon de monter les pièces sur la moto.

LES PARTIES PRESENTEES PEUVENT ETRE UNIQUEMENT REPRESENTATIVES (POUR LA CLARTE DES INSTRUCTIONS UNIQUEMENT).

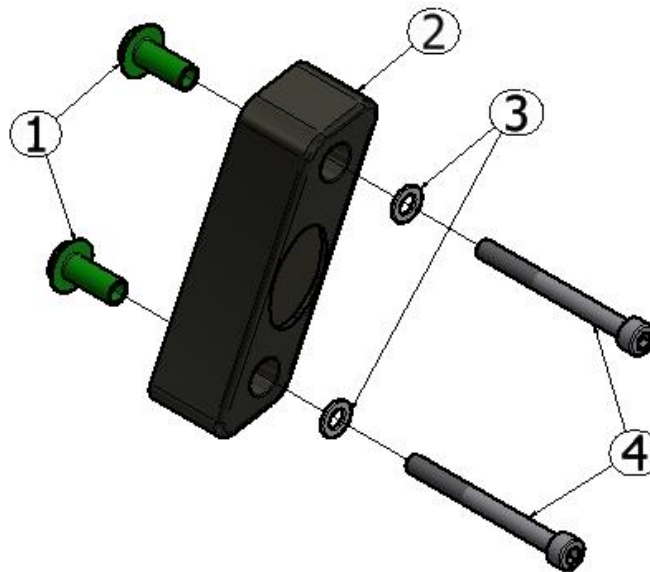



LÉGENDE

- ARTICLE 1 = MANCHON (*PRÉ MONTÉ*) (CS514) (x2).
ARTICLE 2 = SLIDER DE CARTER MOTEUR (ECS0123) (x1).
ARTICLE 3 = M6 RONDELLES (x2)
ARTICLE 4 = M6 x 60mm BOULONS (x2).

OUTILS REQUIS

- Clé à cliquet + douilles de 4 et 5mm.
 - Clé à molette 8mm.



NOTICE DE MONTAGE :

Côté droit (lorsqu'on est assis sur la moto)

- Enlever les 2 boulons du carter moteur du côté droit, voir photo 1
- Si cela n'est pas déjà fait, placer les manchons (Article 1) sur le nouveau slider de carter moteur (Article 2) dans les positions indiquées sur la page 1.
- Monter le slider de carter moteur (Article 2) en position sur le carter moteur du côté droit.
- Insérer un boulon (article 4) avec une rondelle (article 3) dans chaque trou de fixation du slider de carter moteur. Serrer les 2 boulons de façon égale, à la valeur maximale de 15Nm.
- Placer le sticker dans le profil dédié du slider.
- Veiller à ce que l'ensemble corresponde au schéma présenté en page 1.

Issue 1 24/08/2017 (HH)

Notice disponible au téléchargement sur www.rg-racing.com

CONSUMER NOTICE

The catalogue description and any exhibition of samples are only broad indications of the Products and R&G may make design changes which do not diminish their performance or visual appeal and supplying them in such state shall conform to the order. The

R&G Racing
Unit 1, Shelley's Lane, East Worldham, Alton, Hampshire, GU34 3AQ
Tel: +44 (0)1420 89007 Fax: +44 (0)1420 87301 www.rg-racing.com Email: info@rg-racing.com



Buyer acknowledges no representation or warranty (other than as to title) has been given or will apply to the Products other than those in R&G's order or confirmation and the Buyer confirms it has chosen the Products as being of merchantable quality and suitable for its particular purposes. Where R&G fits the Products or undertakes other services it shall exercise reasonable skill and care and rectify any fault free of charge unless the workmanship has been disturbed. The Buyer is responsible for ensuring that the warranty on the motorcycle is not affected by the fitting of the Products. On return of any defective Products R&G shall at its option either supply a replacement or refund the purchase money but shall not be liable if the Products have been modified or used or maintained otherwise than in accordance with R&G's or manufacturer's instructions and good engineering practice or if the defect arises from accident or neglect. Other than identified above and subject to R&G not limiting its liability for causing death and personal injury, it shall not be liable for indirect or consequential loss and otherwise its liability shall be limited to the amounts paid by the Buyer for the Products or the fitting or service concerned. These terms do not affect the Buyer's statutory rights.

R&G RACING RETURNS POLICY (NON-FAULTY GOODS)

Returns must be pre-authorized (if not pre-authorized the return will be rejected). Goods may only be returned direct to us if they were purchased direct from us (customer must prove if necessary). Otherwise to be returned to original vendor. Goods must be in resellable condition, in the opinion of R&G Racing. All returns are subject to a 25% restocking and handling fee (25% of the gross value exc. P&P – at the prevailing price at time of purchase). The customer must pay any and all carriage charges. No returns of discontinued products, unless within 14 days of purchase. This policy does not affect your statutory rights and does not refer to faulty goods.